

DT SWISS

D 232 / D 232 ONE

TECHNICAL MANUAL

V2023.02

1. GENERAL.....	3
1.1 VALIDITY.....	3
1.2 SAFETY.....	3
1.3 TARGET GROUP.....	3
1.4 LAYOUT.....	3
1.5 DT SWISS MANUAL CONCEPT.....	3
1.6 GENERAL MAINTENANCE INFORMATION.....	4
1.7 ENVIRONMENTAL PROTECTION.....	4
1.8 EXCLUSION OF LIABILITY.....	4
1.9 WARRANTY.....	4
2. OVERVIEW.....	5
3. SERVICE KITS.....	7
4. SERVICE AND CARE.....	14
4.1 SAFETY.....	14
4.2 SERVICE INTERVALS.....	14
4.3 CARE.....	14
5. TROUBLE SHOOTING.....	15
6. SMALL SERVICE.....	18
6.1 REMOVING THE SEAT POST.....	18
6.2 CLEANING THE PARTS.....	21
6.3 FITTING THE SEAT POST.....	22
6.4 CHECK THE FUNCTIONALITY.....	24
7. FULL SERVICE.....	25
7.1 REMOVING THE SEAT POST.....	25
7.2 DISASSEMBLING THE SEAT POST.....	27
7.3 ASSEMBLING THE SEAT POST.....	32
7.4 FITTING THE SEAT POST.....	40

1. GENERAL

1.1 VALIDITY

This manual describes the component specified on the front page and the footer. This manual is valid for the design of the product as of 14.02.23. Deviations are possible and all items are subject to technical changes.

1.2 SAFETY

The safety instructions are classified as follows:



DANGER

...indicates a hazardous situation that, if not avoided, will result in death or serious injury.



CAUTION

... indicates a hazard with a medium level of risk which, if not avoided, may result in minor or moderate injury.



NOTE

... indicates a potentially hazardous situation that may result in damage to property.

1.3 TARGET GROUP

This manual is intended for the user of the component and dealers. This manual offers the experienced user the possibility to carry out minor service work himself. If you have any doubts about your own abilities, you should definitely contact an expert or a DT Swiss Service Center. Any warranty claims will lapse if work is not carried out properly.

1.4 LAYOUT

The cover page and the footing provide information about the type of product and manual as well as the version of the manual. The DT Swiss contact details can be found on the back. A list of all DT Swiss service centers can be found at www.dtswiss.com.

This manual is intended for being printed as an A5 booklet. Only print this manual if electronic usage is not possible.

1.5 DT SWISS MANUAL CONCEPT

The DT Swiss manuals are split into the following types of manuals:

- User Manual: Information for the end user on how to install and use the component.
- Technical Manual: Detailed information for the end user and the dealer on how to maintain the component, spare parts and technical data.

1.6 GENERAL MAINTENANCE INFORMATION

Unless otherwise specified, moving parts, threads, O-rings and sealings must be greased before assembly.

CLEANING

For an optimal result of the maintenance work, every component that will be disassembled must be cleaned. Only use cleaners and degreasers which do not damage the components. Especially the cleaning of O-rings and sealings requires mild cleaners. Observe the instructions for use of the respective cleaner.

DT Swiss recommends the following cleaners:

- Motorex Rex
- Motorex Swissclean
- Motorex OPAL 2400, 3000 OPAL, OPAL 5000

Use soap water or similar mild cleaners for external cleaning.

TOOLS

To ensure a damage-free mounting and dismounting of the components, only use the tools which are mentioned in this manual. Special tools are indicated at the beginning of a chapter in the table "Required material".

The use of different tools is at the discretion of the user. If components are damaged by the usage of differing tools, the user is liable.

DT Swiss special tools are precision tools. Damage-free mounting and dismounting of the components can only be ensured if the tools are working properly and if the condition of the tools are perfect. Always keep the tools in their original packaging or adequate devices to prevent damage.

1.7 ENVIRONMENTAL PROTECTION

The statutory regulations shall apply. Whenever possible, avoid creating waste. Waste, especially carbon, lubricants, cleaners and any other fluids must be disposed in an environmentally compatible manner.

Only print this manual if electronic usage is not possible.

1.8 EXCLUSION OF LIABILITY

The activities listed in this manual may only be carried out by persons with sufficient specialist knowledge. The user is liable for any damage or consequential damage caused by wrongly maintained or installed components. If you have doubts, please contact an expert or your region's DT Swiss pro level service center.

1.9 WARRANTY

Warranty conditions can be found at www.dtswiss.com.

2. OVERVIEW

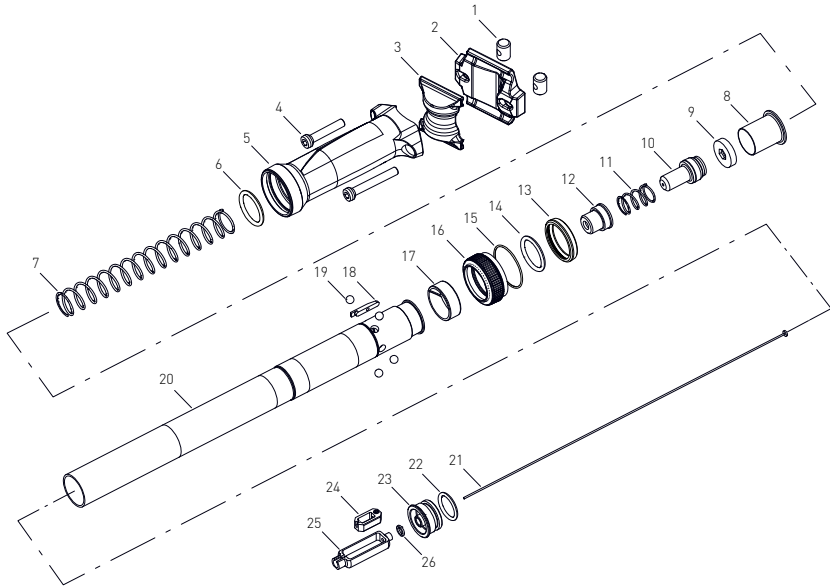

Pos	Description	included in Service Kit
1	barrel nut (2x)	D232 SEAT CLAMP KIT / D232 SEAT CLAMP SCREW KIT
2	upper seat clamp	D232 / D232 ONE SEAT CLAMP KIT
3	lower seat clamp	D232 / D232 ONE SEAT CLAMP KIT
4	seat clamp screw (2x)	D232 / D232 ONE SEAT CLAMP KIT / SEAT CLAMP SCREW KIT
5	slider tube	D232 / D232 ONE SLIDER TUBE KIT
6	O-ring	D232 GUIDING KIT
7	coil spring	D232 REPLACEMENT SPRING
8	outer coil spring guide	D232 GUIDING KIT
9	upper stop release piston	D232 LATCH SYSTEM KIT
10	release piston	D232 LATCH SYSTEM KIT
11	coil spring release piston	D232 LATCH SYSTEM KIT
12	guide for release piston	D232 LATCH SYSTEM KIT
13	raster ring**	D232 LATCH SYSTEM KIT / RASTER RING KIT
14	O-ring	D232 GUIDING KIT
15	O-ring	D232 SLIDER TUBE NUT KIT / SLIDER TUBE NUT O-RING KIT
16	lock nut	D232 SLIDER TUBE NUT KIT
17	guide ring	D232 GUIDING KIT
18	guide key	D232 / D232 ONE SLIDER TUBE KIT
19	latch (5x)	D232 LATCH SYSTEM KIT / D232 BALL REPL. KIT*
20	seat tube	D232 / D232 ONE SEAT TUBE REPLACEMENT*
21	internal actuating spoke	D232 QUICK CONNECTOR KIT
22	O-ring	D232 QUICK CONNECTOR KIT
23	lower seat tube cover	D232 / D232 ONE QUICK CONNECTOR CAP KIT
24	quick release slider	D232 QUICK CONNECTOR KIT
25	quick release housing	D232 QUICK CONNECTOR KIT
26	O-ring	D232 QUICK CONNECTOR KIT

*only available for DT Swiss Service Centers

**There are two versions of the raster ring: cylindrical and conical. If a cylindrical raster ring is installed in your D 232 and your D 232 drops on its own without pressing the remote lever, contact a DT Swiss Service Center.

conical

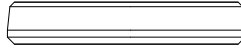
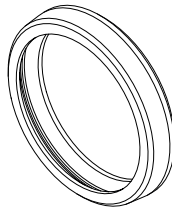

cylindrical

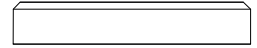
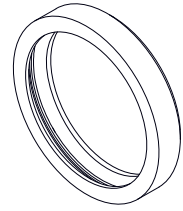

3. SERVICE KITS

D232 SLIDER TUBE KIT

Item No: DWKD232S30508S

1x guide key

1x slider tube aluminum

1x spring guide

The spring guide is pre-assembled in the slider tube.

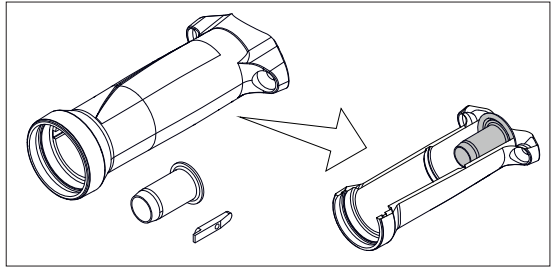

D232 ONE SLIDER TUBE KIT

Item No: DWKD232S30507S

1x guide key

1x slider tube carbon

1x spring guide

The spring guide is pre-assembled in the slider tube.

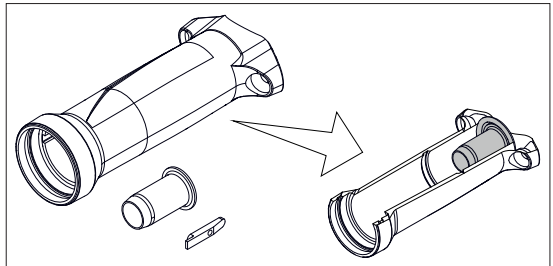

D232 LATCH SYSTEM KIT

Item No: DWKD232X30510S

1x upper stop for release piston

1x release piston

1x coil spring release piston

1x guide for release piston

1x raster ring

5x latch

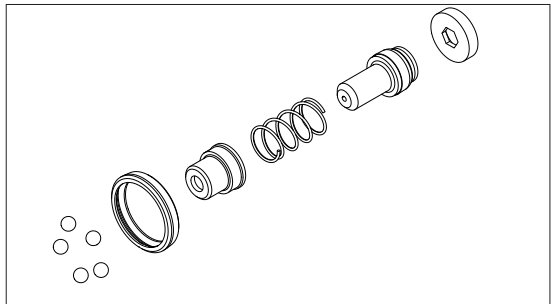

D232 RASTER RING KIT

Item No: DXXXXXXX24677S

1x raster ring

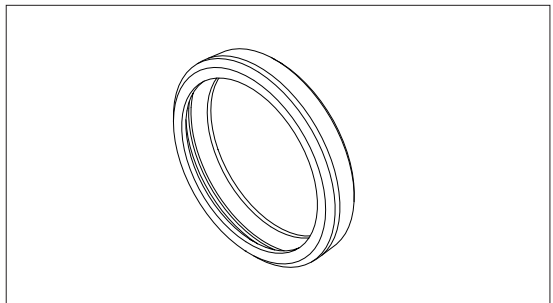

D232 QUICK CONNECTOR CAP KIT Ø27.2

Item No: DWKD232X30511S

1x lower seat tube cover Ø27.2 mm

1x O-ring Ø18 x 2.5 mm

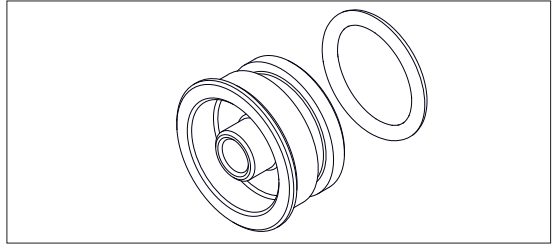

D232 QUICK CONNECTOR CAP KIT Ø30.9

Item No: DWKD232X30512S

1x lower seat tube cover Ø30.9 mm

1x O-ring Ø22 x 2.5 mm

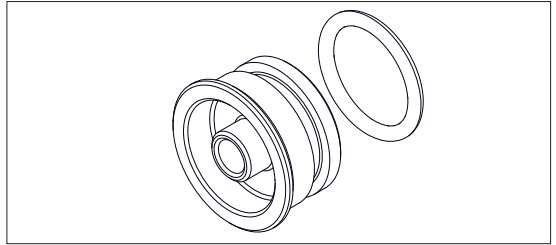

D232 ONE QUICK CONNECTOR CAP KIT Ø27.2

Item No: DWKD232X30514S

1x lower seat tube cover Ø27.2 mm

1x O-ring Ø18 x 2.5 mm

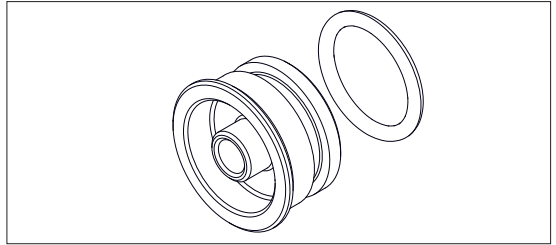

D232 ONE QUICK CONNECTOR CAP KIT Ø30.9

Item No: DWKD232X30513S

1x lower seat tube cover Ø30.9 mm

1x O-ring Ø22 x 2.5 mm

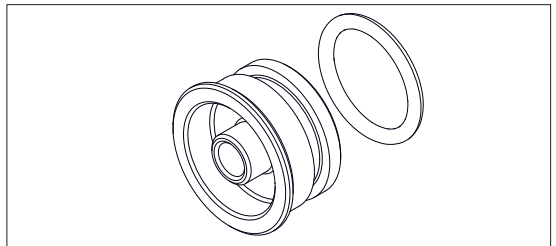

D232 QUICK CONNECTOR KIT

Item No: DWKD232X30515S

1x quick release housing

1x O-ring Ø6 x 1.5 mm

1x quick release slider

2x threaded pin M4 x 4 mm

1x Internal actuating spoke

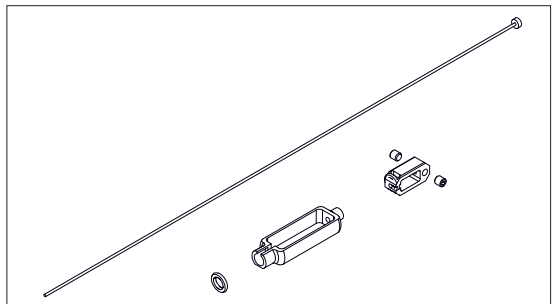

D232 SLIDER TUBE NUT KIT

Item No: DWKD232X30516S

1x guide ring $\varnothing 28 \times 32 \times 10$ mm

1x lock nut

1x wiper seal

1x O-ring

The wiper seal, O-ring and guide ring are pre-assembled.

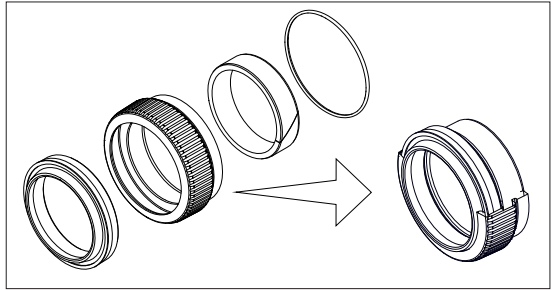

D232 GUIDING KIT

Item No: DWKD232X30517S

1x guide ring $\varnothing 25 \times 28 \times 10$ mm

2x O-ring $\varnothing 23 \times 3$ mm

1x outer coil spring guide
 $\varnothing 27.5 \times 20.9 \times 27$ mm

1x guide ring $\varnothing 28 \times 32 \times 10$ mm

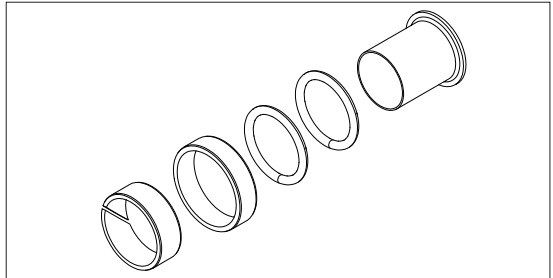

D232 ONE CARBON SEAT CLAMP KIT

Item No: DWKD232C30518S

1x upper seat clamp carbon

1x lower seat clamp carbon

2x barrel nut

1x seat clamp screw Ti
M6 / $\varnothing 10 \times 36$ mm

1x seat clamp screw Ti
M6 / $\varnothing 10 \times 46$ mm

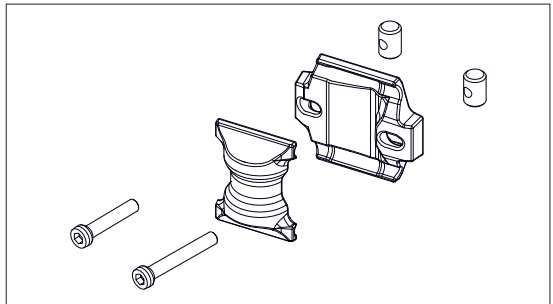

D232 ALUMINIUM SEAT CLAMP KIT

Item No: DWKD232S30519S

1x upper seat clamp aluminum

1x lower seat clamp aluminum

2x barrel nut

1x seat clamp screw
M6 / $\varnothing 10 \times 36$ mm

1x seat clamp screw
M6 / $\varnothing 10 \times 46$ mm

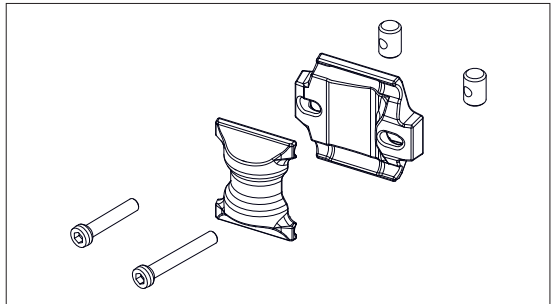

D232 ONE TITAN SEAT CLAMP SCREW KIT

Item No: DWKD232S30520S

2x barrel nut

1x seat clamp screw Ti
M6 / Ø10 x 36 mm

1x seat clamp screw Ti
M6 / Ø10 x 46 mm

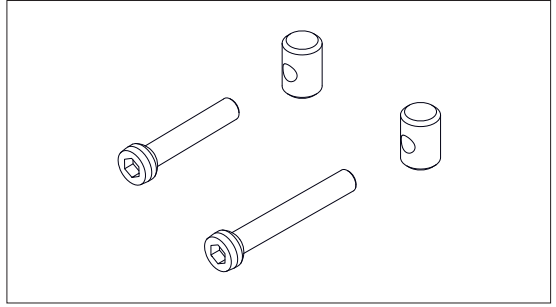

D232 STEEL SEAT CLAMP SCREW KIT

Item No: DWKD232N30521S

2x barrel nut

1x seat clamp screw
M6 / Ø10 x 36 mm

1x seat clamp screw
M6 / Ø10 x 46 mm

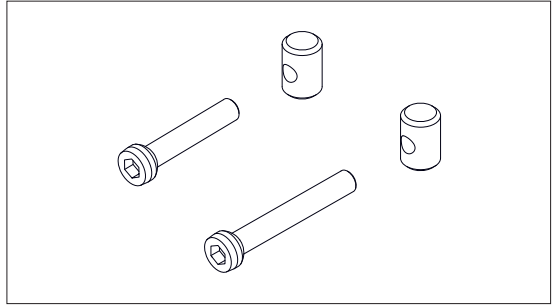

D232 REPLACEMENT SPRING

Item No: DWKD232N30522S

1x coil spring

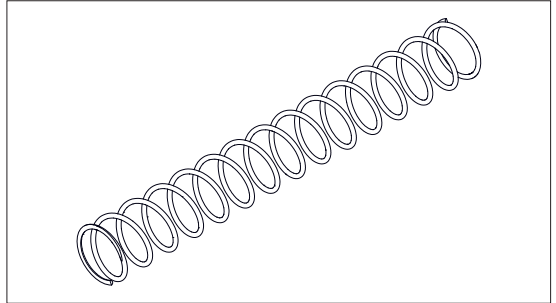

D232 SEAT TUBE REPLACEMENT Ø27.2

Item No: DWKD232S30523S

Only available for DT Swiss service centers

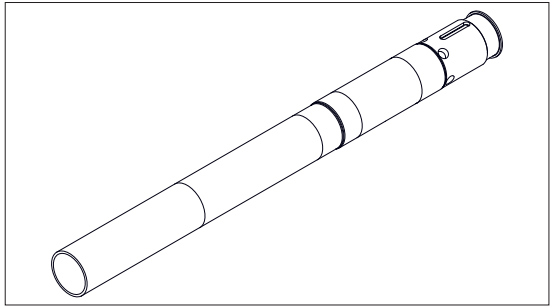

D232 SEAT TUBE REPLACEMENT Ø30.9

Item No: DWKD232S30524S

Only available for DT Swiss service centers

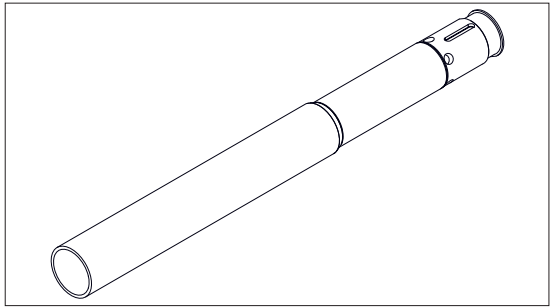

**D232 ONE SEAT TUBE REPLACEMENT
Ø27.2**

Item No: DWKD232C30525S

Only available for DT Swiss service centers

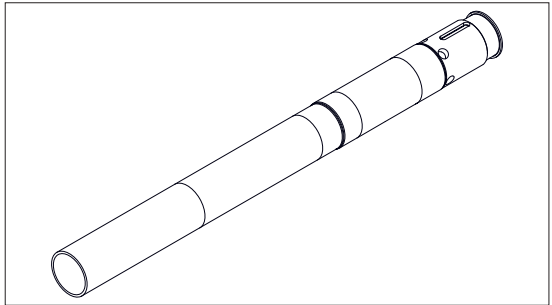

**D232 ONE SEAT TUBE REPLACEMENT
Ø30.9**

Item No: DWKD232C30526S

Only available for DT Swiss service centers

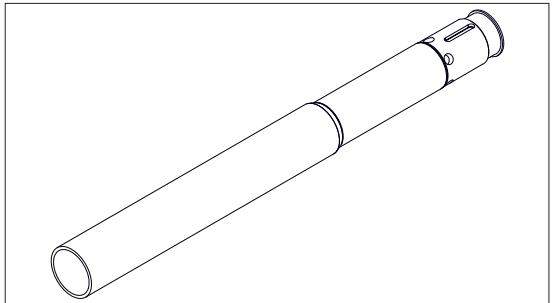

D232 BALL REPLACEMENT KIT

Item No: DWKD232N30527S

10 x latch

Only available for DT Swiss service centers

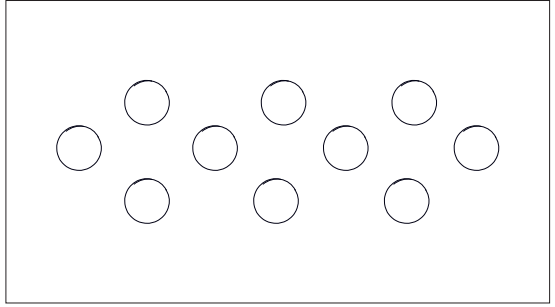

D232 SLIDER TUBE NUT O-RING KIT

Item No: DWKD232X34575S

5x O-ring slider tube nut

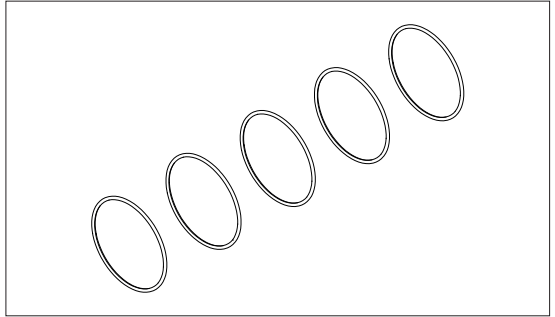

L1 REMOTE LEVER

Item No: LL1XX4LXXXSA29724S

1x remote lever

1x shift cable Ø1.1 mm, length 2100 mm

2x cable end crimp

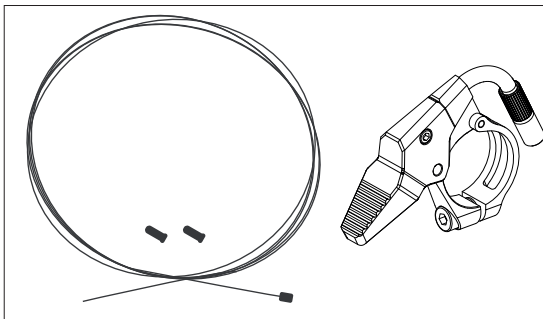

L1 REMOTE LEVER SHORT

Item No: LL1BY4LXXXS035546S

1x handlebar clamp

1x L2 remote lever

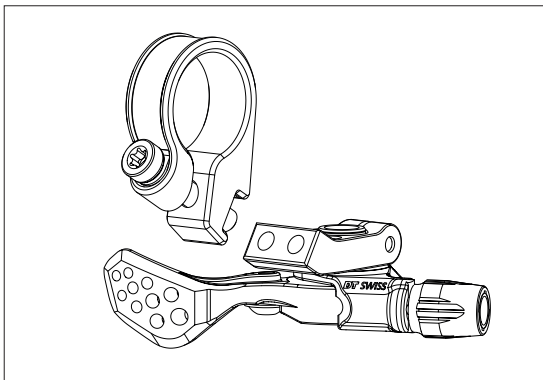

4. SERVICE AND CARE

4.1 SAFETY



DANGER

RISK OF INJURY DUE TO WRONG MAINTENANCE OF THE SEAT POST!

Incorrect maintenance or assembly of the seat post can lead to incorrect function!

- Maintenance and assembly may only be done by a skilled professional.
- In case of any doubt, contact a DT Swiss service center.
- Only use original spare parts.

4.2 SERVICE INTERVALS

If service intervals are not respected, any warranty claims can be denied.

Task	Interval
Full service see "7. Full service" on page 25	Annually or after 200 operating hours
Small service see "6. Small Service" on page 18	50 operating hours more frequently in case of extreme operating conditions.
Check the seat post for damage and cracks. If there is any damage, contact the DT Swiss service center.	Before and after every ride and after a crash
Check the fastening is correct / check tightening torques	Before each ride
Check the functionality	Before each ride
Seat post care (see below)	After each ride

4.3 CARE

The following care and cleaning instructions must be observed:

- Clean the seat post with a damp cloth after each ride. Remove dirt accumulations in the area of the wiper seal.
- Never use aggressive cleaners that damage the wiper seal.
- Never use high pressure cleaners. Water and dirt can get into the seat post and damage it!
- Remove all visible, dried dirt from the area of the wiper seal. This will prevent dirt from getting into the seat post.
- It is not necessary to grease the seat post in the area of the wiper seal.

5. TROUBLE SHOOTING

Issue	Reason	Solution
Seat post does not compress or extend properly.	dirty / too little grease	Small service (details, see chap. 6 / page 18).
	O-ring (No. 13) crushed / defective	Disassemble the seat post completely and clean all parts. Replace guiding kit (details, see chap. 7 / page 25).
	wiper seal of lock nut damaged	Disassemble the seat post completely and clean all parts. Replace slider tube nut kit (details, see chap. 7 / page 25).
	release piston jammed	Disassemble the seat post completely and clean all parts. Replace latch system kit (details, see chap. 7 / page 25).
Seat post blocked / does not release.	cable tension too low	increase tension of the cable
	cable torn	replace cable
	cable unhooked from the quickconnector	Dismount the seat post and attach the cable.
	quickconnector damaged	Replace the quickconnector kit (details, see chap. 7 / page 25).
	lower seat tube cover damaged	Install a new seat tube cover (details, see chap. 7 / page 25).
	connection of quickconnector and actuating spoke loose	Clamp the actuating spoke to the quickconnector (details, see "Mounting the quickconnector" on page 35).
	actuating spoke defective	Replace the actuating spoke (details, see "Mounting the quickconnector" on page 35).
	release piston jammed	Disassemble the seat post completely and clean all parts. Replace the latch system kit (details, see chap. 7 / page 25).
	O-ring (No. 13) crushed / defective	Disassemble the seat post completely and clean all parts. Replace the guiding kit (details, see chap. 7 / page 25).
raster ring tilted due to loose lock nut	Check the tightness of the lock nut, check whether the O-ring (Nr. 14) is damaged or present. Align the raster ring correctly and tighten the lock nut hand-tight. When the lock nut is tightened, there must be no air gap between the lock nut and the slider tube.	

Issue	Reason	Solution
Seat post does not lock correctly in the upper position. or / and Seat post releases without pushing the remote lever down.	dirty / too little grease	Small service (details, see chap. 6 / page 18).
	cable tension too high	Reduce the tension of the cable.
	tension of the actuating spoke on the quickconnector too high	Reduce the tension of the actuating spoke (details, see "Mounting the quickconnector" on page 35).
	release piston jammed	Disassemble the seat post completely and clean all parts. Replace the latch system kit (details, see chap. 7 / page 26).
	wear of the locking mechanism	
	coil spring defective	Small service and exchange of the coil spring (details, see chap. 6 / page 18).
	raster ring tilted due to loose lock nut	Check the tightness of the lock nut, check whether the O-ring (Nr. 14) is damaged or present. Align the raster ring correctly and tighten the lock nut hand-tight. When the lock nut is tightened, there must be no air gap between the lock nut and the slider tube.
cylindrical raster ring (see "2. Overview" on page 5) canted	Contact a DT Swiss service center.	
Seat post does not lock correctly in the lower position. or / and Seat post automatically releases upwards.	seat post has not locked correctly because there is not enough force on the seat post when lowering	Compress with more force until the mechanical stop.
	dirty / too little grease	Small service (details, see chap. 6 / page 18).
	cable tension too high	Reduce the tension of the cable.
	tension of the actuating spoke on the quickconnector too high	Reduce the tension of the actuating spoke (details, see "Mounting the quickconnector" on page 35).
	release piston jammed	Disassemble the seat post completely and clean all parts. Replace the latch system kit (details, see chap. 7 / page 25).
	wear of the locking mechanism	
	wear of the locking groove in the slider tube	Disassemble the seat post completely and clean all parts. Replace the slider tube kit (details, see chap. 7 / page 25).
O-ring (No. 13) crushed / defective	Disassemble the seat post completely and clean all parts. Replace guiding kit (details, see chap. 7 / page 25).	
axial play of the slider tube in one or both locking positions	cable tension too high	Reduce the tension of the cable.
	tension of the actuating spoke on the quickconnector too high	Reduce the tension of the actuating spoke (details, see "Mounting the quickconnector" on page 35).

Issue	Reason	Solution
strong rotational play of the slider tube	wear of the guide key	Disassemble the seat post completely and clean all parts. Replace slider tube kit (details, see chap. 7 / page 25).
	wear of the locking groove in the slider tube	
seat post makes noise while riding	dirty / too little grease	Small service (details, see chap. 6 / page 18).
	seat clamp dirty	Disassemble and clean the seat clamp .
	seat post clamp dirty	Remove the seat post, clean the surfaces, apply grease or assembly paste and install (details, see chap. 7 / page 25).
	The cause of the noise does not come from the seat post, but from another component of the bicycle.	
cable runs rough high actuating forces at the remote lever cable blocked	dirty / too little grease	Small service (details, see chap. 6 / page 18).
	cable or cable housing dirty or defective	Replace cable or cable housing (details, see user manual at dtswiss.com).
	guide of the remote lever defective	Replace remote lever (details, see user manual at dtswiss.com).
	release piston jammed	Disassemble the seat post completely and clean all parts. Replace latch system kit (details, see chap. 7 / page 25).
	incorrect use of the seat post: seat post is lowered under full load	Relieve the seat post briefly while operating the remote lever.
play of the remote lever	cable tension too low	Increase tension of the cable.
	guide of the remote lever defective	Replace the remote lever (details, see user manual at dtswiss.com).
strong radial play in riding direction	excessive wear on the guides	Disassemble the seat post completely and clean all parts. Replace guiding kit / slider tube nut kit (details, see chap. 7 / page 25).
seat tube damaged	crash	Disassemble the seat post completely, replace seat tube* (details, see chap. 7 / page 25).
seat clamps damaged or broken	crash	Replace the seat clamp .
seat clamp screw defective	wrong tool / torque exceeded	Replace the seat clamp screws .
seat clamp screws loosen	torque wrench	Apply medium strength thread lock on the seat clamp screws.

In case of further issues or questions, please contact your dealer or a DT Swiss service center.

*only available for DT Swiss Service Centers

6. SMALL SERVICE

A small service can be carried out without removing the seat post from the bike frame and without removing the saddle.

A small service should be carried out in the following cases:

- Interval for a small service has elapsed (50 operating hours).
- Malfunctions (see also "5. Trouble Shooting" on page 15), e.g.
 - seat post does not compress or extend properly
 - seat post does not lock correctly in the upper/lower position
 - seat post releases without pushing the remote lever downwards/upwards
 - seat post makes noises while riding
 - shift cable runs sluggishly / high actuating forces on remote lever / shift cable blocked

Preparatory Steps

Make sure that the seat post is in the extended position. If not, extend the seat post by pressing the remote lever.

Clean the seat post.

Check all functions of the seat post. If malfunctions occur, observe the information in the table in chapter "5. Trouble Shooting" on page 15!

Required Material	Specification	Quantity
universal grease	Slick Honey	as required
cleaners	Motorex Rex, Motorex Swissclean, Motorex OPAL 2400, OPAL 3000, OPAL 5000 or similar	as required

6.1 REMOVING THE SEAT POST

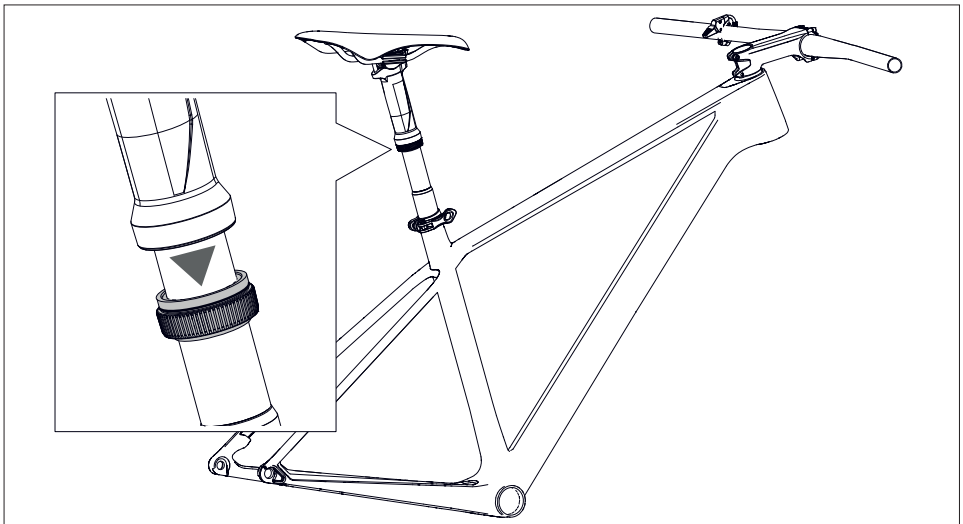

1. Press the saddle down slightly and unscrew the lock nut from the slider tube by hand.

2. Pull the slider tube off the seat tube.
3. Pull the coil spring out of the seat tube.

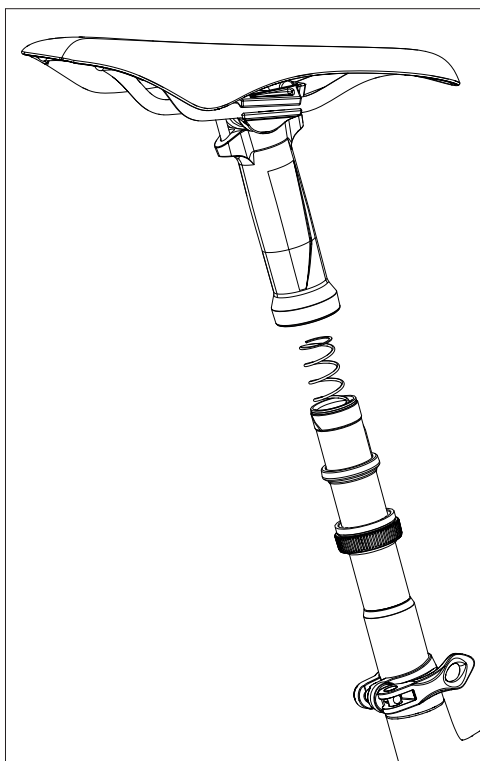

4. Remove the guide ring from the upper end of the seat tube.

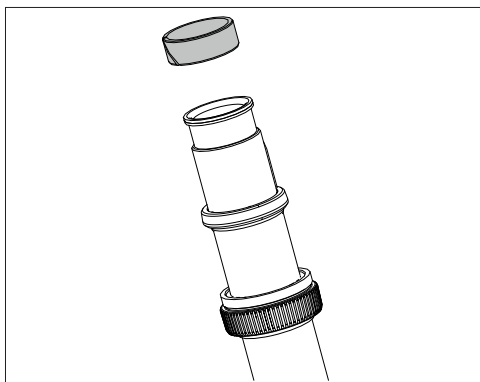

5. Operate the remote lever and slide the raster ring downwards when the remote lever is pushed.

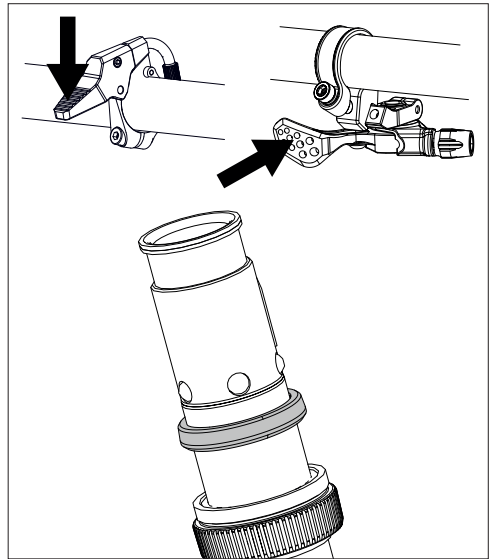

6. Take the five latches out of the recesses in the seat tube.
TIP: A magnet makes it easier to remove the latches.

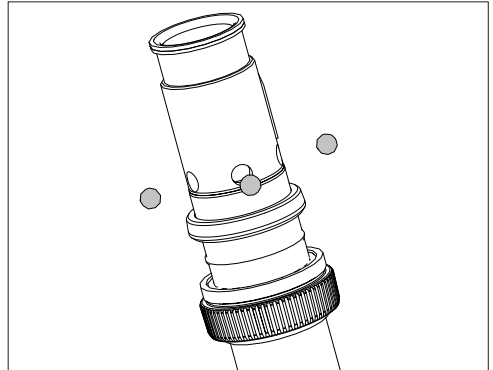

7. Pull the spring guide out of the seat tube.

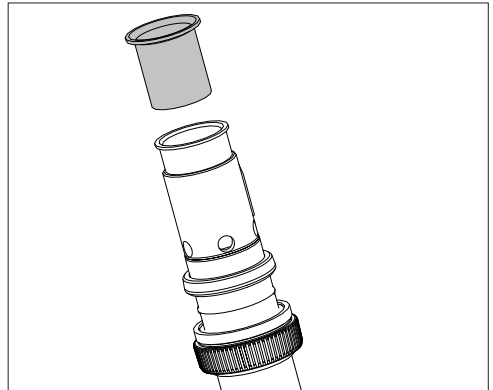

6.2 CLEANING THE PARTS

1. Clean all parts with an appropriate cleaner.
We recommend one of the following cleaners:
 - Motorex Rex
 - Motorex Swissclean
 - Motorex OPAL 2400, 3000 OPAL, OPAL 5000
2. Check all parts for excessive wear and replace worn parts if necessary.
3. Check that the O-ring on the lock nut is present and undamaged. Fit / replace O-ring if necessary.

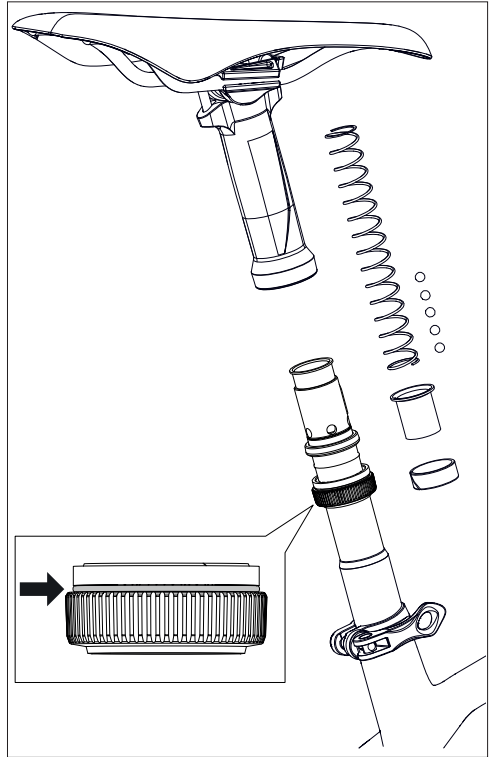

6.3 FITTING THE SEAT POST

1. Lightly grease the inner surface of the seat tube and the spring guide.
2. Push the spring guide into the seat tube.

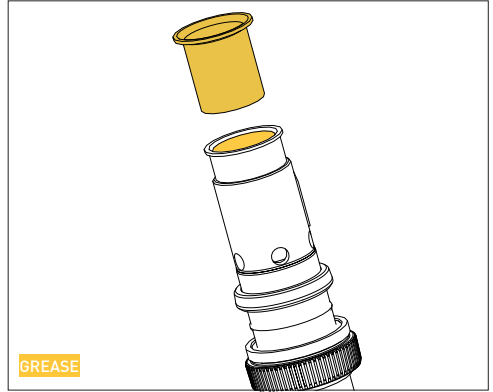

3. Generously grease the recesses for the latches in the seat tube.
4. Insert the five latches into the recesses in the seat tube.
5. Grease the entire area around the latches.

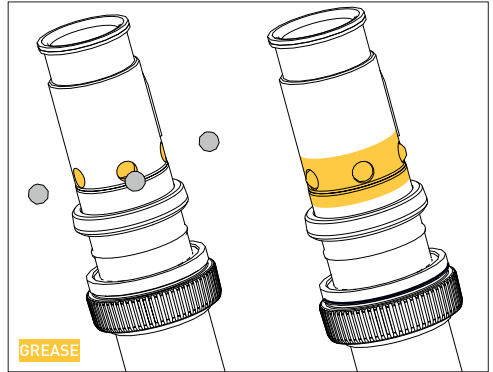

6. Press the remote lever and simultaneously slide the raster ring over the latches.
7. Grease the entire area around the raster ring.

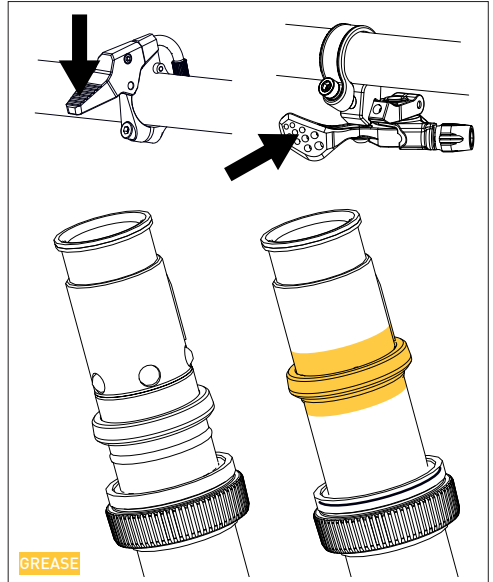

8. Grease the guide ring and the groove for the guide ring in the seat tube.
9. Slide the guide ring on the seat tube.
10. Grease the entire area around the guide ring.

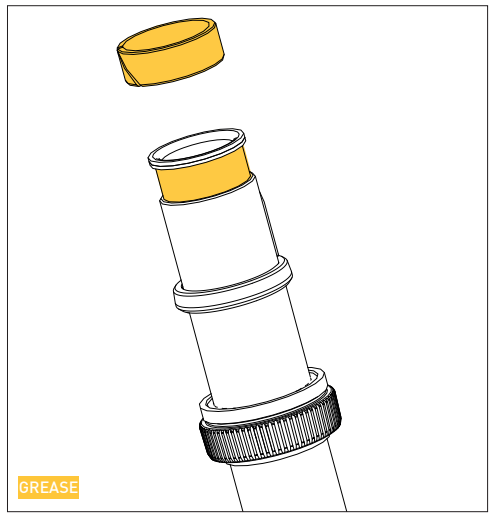

11. Make sure that the entire sliding area of the seat post is greased.
12. Grease the spring and the inner surface of the slider tube.
13. Push the coil spring into the seat tube.
14. Slide the slider tube onto the seat tube. Make sure that the guide key slides into the guide groove of the slider tube.

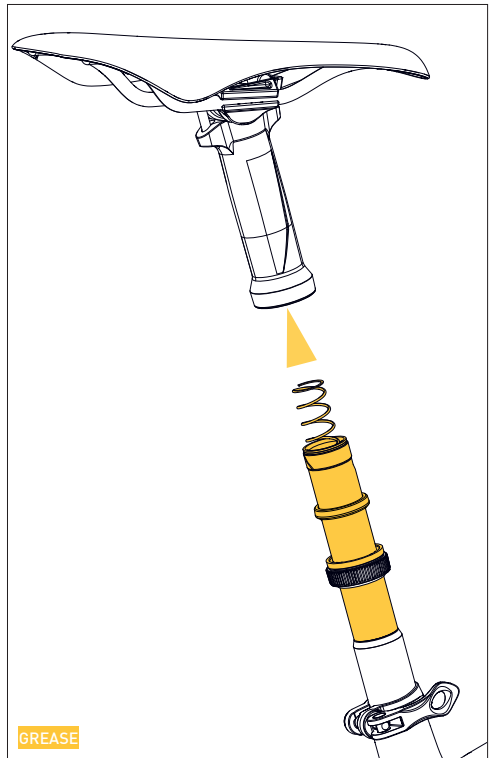

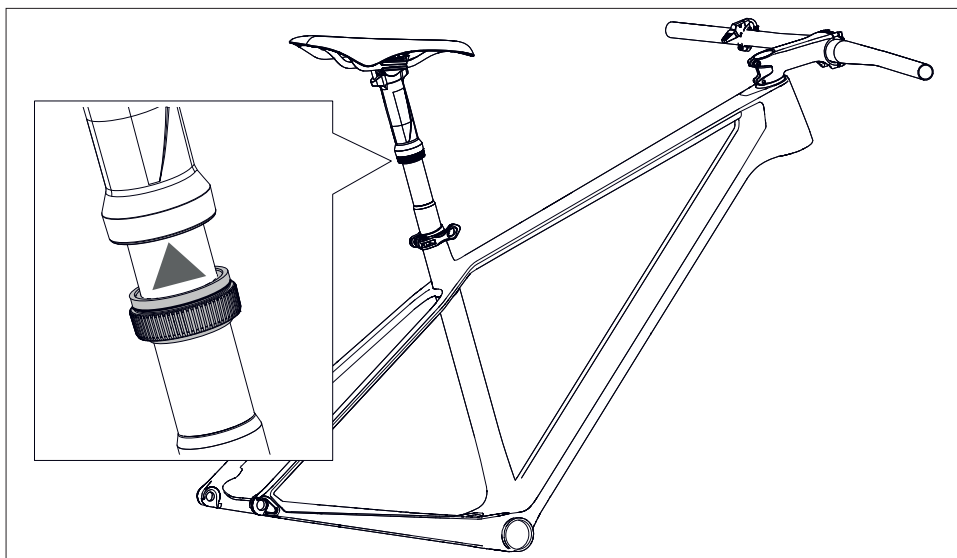

15. Press the saddle down against the spring force and screw the lock nut onto the slider tube.
16. Tighten the lock nut firmly by hand.
 - There must be no visible gap between slider tube and lock nut.
17. Lower the seat post several times and remove excess grease.

6.4 CHECK THE FUNCTIONALITY

1. Check the tension of the cable and adjust the tension if necessary using the cable adjuster on the remote lever.
 - If the tension in the switch cable is too low, there may be some play in the remote lever.
 - If the tension in the switch cable is too high, there may be some vertical play in the seat post.
2. Actuate the remote lever and push the seat post down. Release the remote lever once the seat post is no longer in the top fixed position.
 - It must be possible to push the seat post down with slight resistance.
 - The seat post must latch in the lowered position with a noticeable click.
3. Briefly actuate the remote lever while the seat post is fixed in the lower position. Do not apply a load to the saddle while doing so.
 - The seat post must immediately return to the top position after actuating the remote lever.
 - The seat post must be fixed in the top position; it must not be possible to press it down even with the remote lever pressed.
4. Check that the seat post clamp is clamping correctly: Stand behind your bicycle, grasp the saddle with one hand and attempt to twist the seat post.
 - It must be impossible to twist the seat post.

7. FULL SERVICE

A full service should be carried out in the following cases:

- Interval for a full service has elapsed (annually or after 200 operating hours)
- Replacement of a component due to a malfunction that requires complete disassembly of the seat post. See also "5. Trouble Shooting" on page 15.

7.1 REMOVING THE SEAT POST

Preparatory Steps

Make sure that the seat post is in the extended position. If not, extend the seat post by pressing the remote lever.

Clean the seat post

Check all functions of the seat post.

If malfunctions occur, observe the information in the table in chapter "5. Trouble Shooting" on page 15!

DISMOUNTING SADDLE AND SEAT CLAMP

1. Unscrew both saddle clamp bolts.
2. Pull the saddle upwards with the upper seat clamp.
3. Remove the barrel nuts from the upper seat clamp.

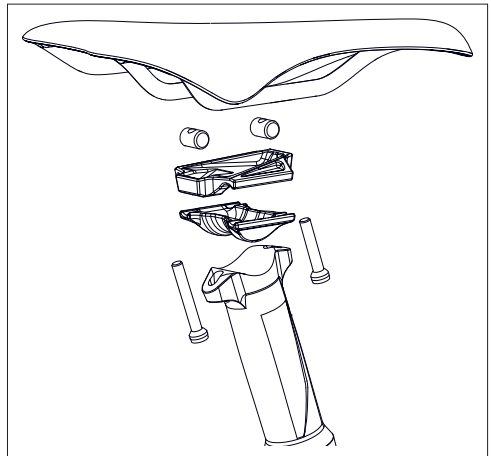

REMOVING THE L1 REMOTE LEVER FROM THE HANDLEBAR

1. Loosen the clamp fixing screw and remove the remote lever from the handlebar.

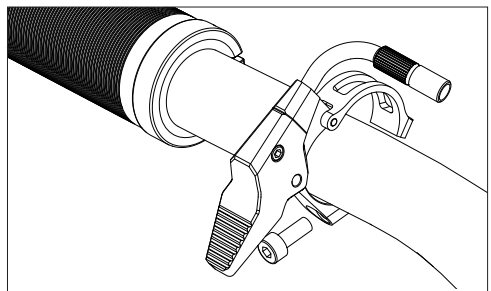

REMOVING THE L1 TRIGGER LEVER FROM THE HANDLEBAR

1. Dismount the grip.
2. Loosen the clamp fixing screw and remove the remote lever from the handlebar.

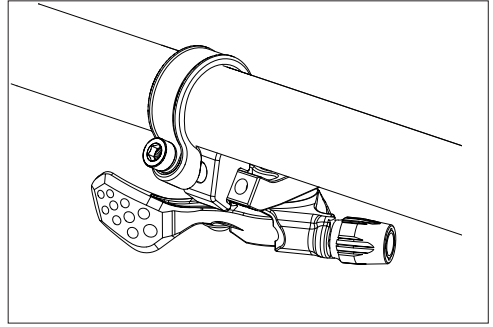

REMOVING THE SEAT POST FROM THE BIKE FRAME

1. Screw the cable adjuster on the remote lever in fully to relieve the tension.
2. If present, release the cable clamps on the bike frame.
3. Open the seat post clamp, pull the seat post carefully out of the bike frame while feeding the cable at the same time.
4. Pull the cable housing on the quickconnector downwards and detach the cable housing.
5. Detach the cable from the quickconnector.

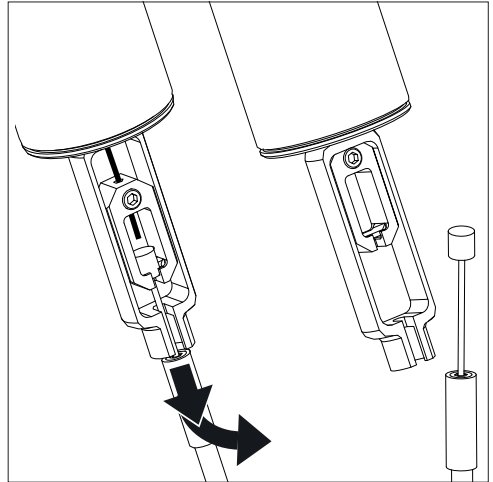

7.2 DISASSEMBLING THE SEAT POST

1. Unscrew the lock nut from the slider tube by hand.

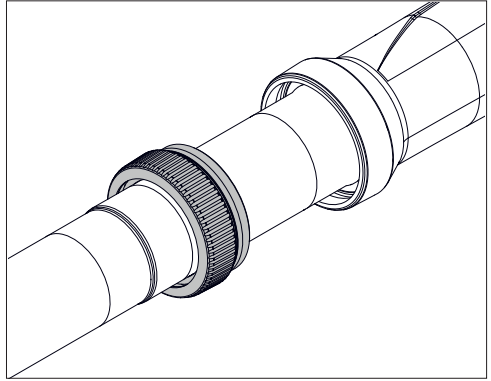

2. Pull the slider tube off the seat tube.
3. Pull the coil spring from the seat tube.

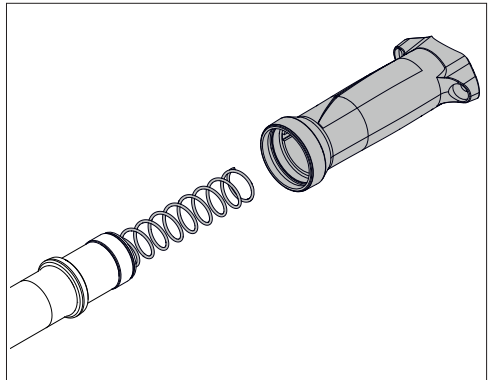

4. Remove the guide ring.

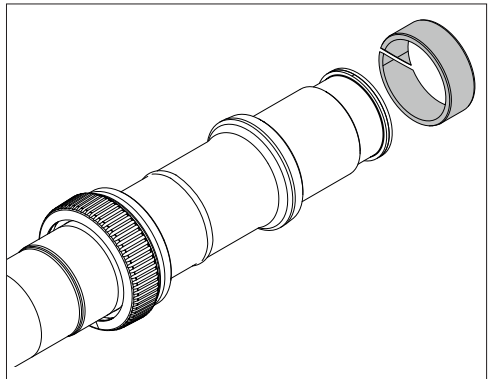

5. Press the guide key out of the seat tube using an M3 screw with a minimum thread length of 5 mm.

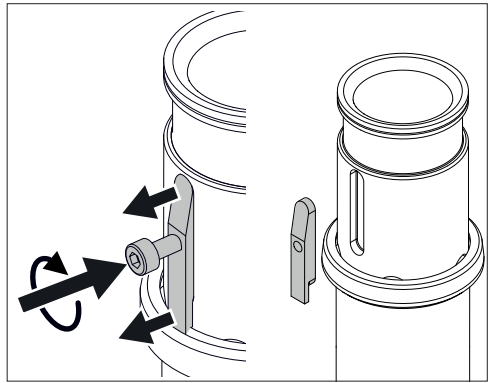

6. Slide a 6 mm hex key from above into the stop of the release piston and press the release piston slightly downwards.

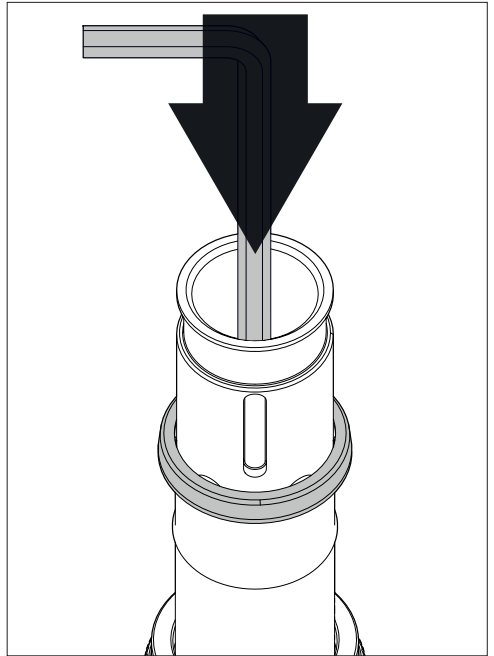

7. Push the raster ring upwards with the release piston pressed down and remove the raster ring from the seat tube.

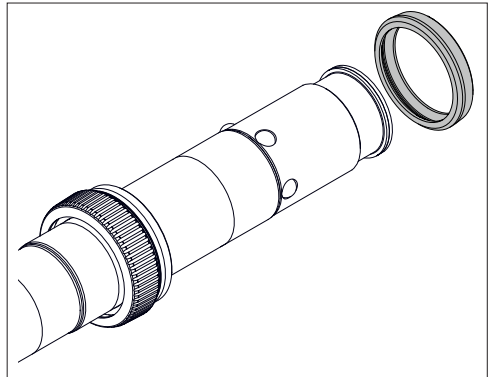

8. Take the five latches out of the recesses in the seat tube.

TIP: A magnet makes it easier to remove the latches.

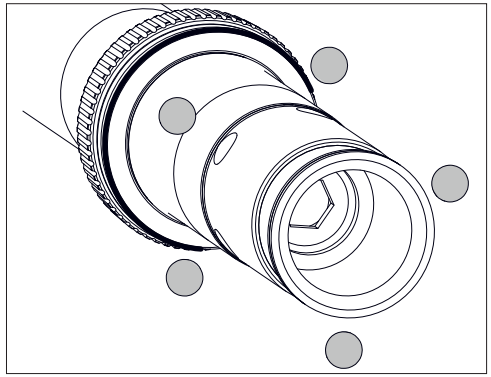

9. Slide the lock nut and O-ring off the seat tube.

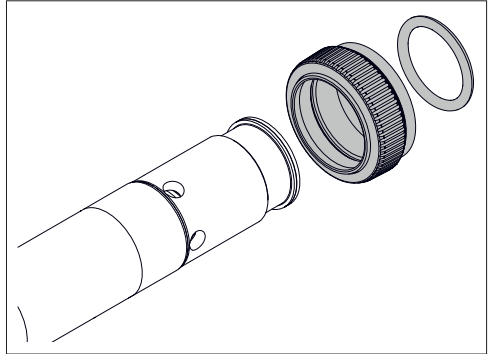

10. Pull the spring guide out of the seat tube.

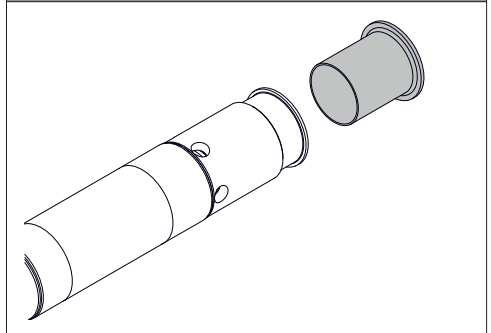

DISMOUNT THE QUICKCONNECTOR

1. Unscrew the clamping screw of the actuating spoke a few turns.

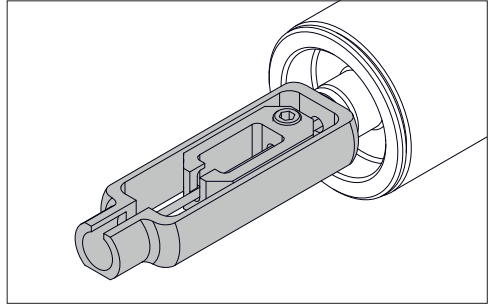

2. Pull the quickconnector with the slider down.
3. Remove the seat tube cover.

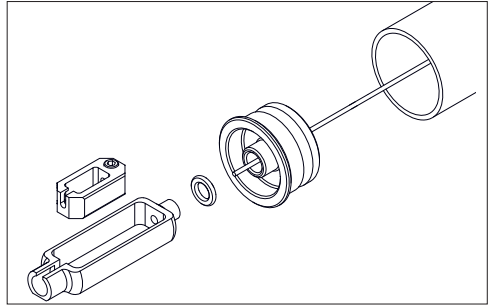

4. Push the actuating spoke upwards and pull the actuating spoke out of the seat tube from the top.

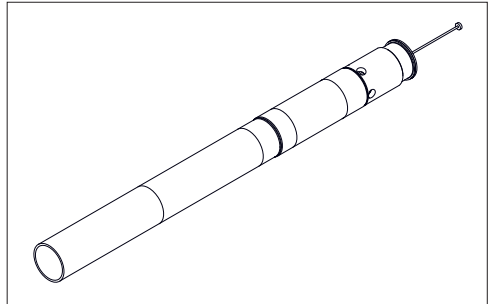

REMOVING THE RELEASE PISTON FROM THE SEAT TUBE

1. Screw the stop of the release piston out of the seat tube using an 8 mm hex key.

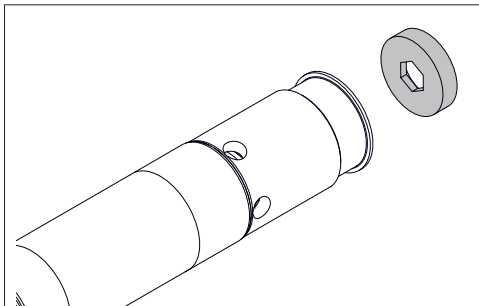

2. Take the release piston, the spring and the guide of the release piston out of the seat tube.

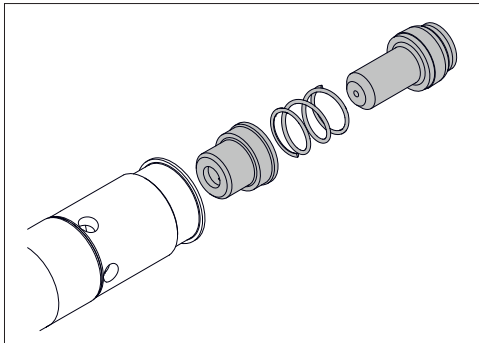

7.3 ASSEMBLING THE SEAT POST

MOUNTING THE LOCK NUT

Required Material	Specification	Quantity
SLIDER TUBE NUT KIT	Art. No.: DWKD232X30516S Details, see "Service Kits" on page 7	1*
D232 SLIDER TUBE NUT O-RING KIT	Art. No.: DWKD232X34575S Details, see "Service Kits" on page 7	1*
universal grease	Slick Honey	as required

*The service kit only needs to be replaced if there is a seat post malfunction (see "Trouble Shooting" on page 15). In case of malfunction, all parts of the required service kit should be replaced.

1. Check that the O-ring on the lock nut is present and undamaged. Fit / replace O-ring if necessary.
2. Grease the inner surface of the lock nut, the sliding surface of the seat tube and the O-ring.
3. Slide the lock nut and O-ring onto the seat tube.

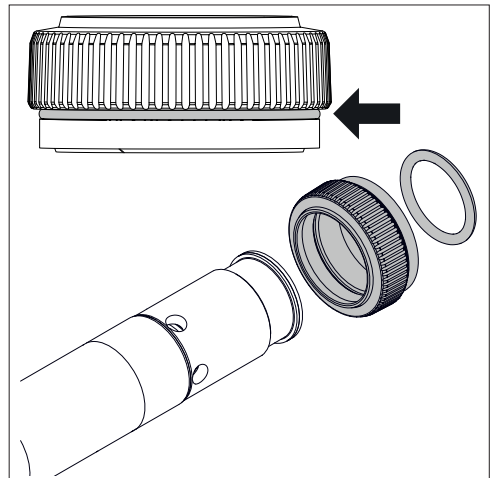

MOUNTING THE RELEASE MECHANISM

Required Material	Specification	Quantity
D232 LATCH SYSTEM KIT	Art. No.: DWKD232X30510S Details, see "Service Kits" on page 7	1*
universal grease	Slick Honey	as required

*The service kit only needs to be replaced if there is a seat post malfunction (see "Trouble Shooting" on page 15). In case of malfunction, all parts of the required service kit should be replaced.

1. Grease the guide, spring, release piston and inner surface of the seat tube.
2. Insert the guide, spring and release piston into the seat tube.

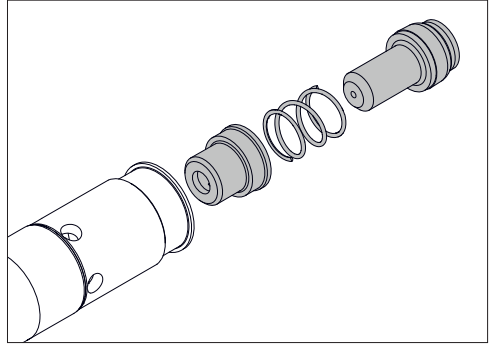

3. Push the stop for the release piston into the seat tube and tighten the stop with an 8 mm hex key to a torque of 4 Nm.
→ The recess of the stop must point upwards.

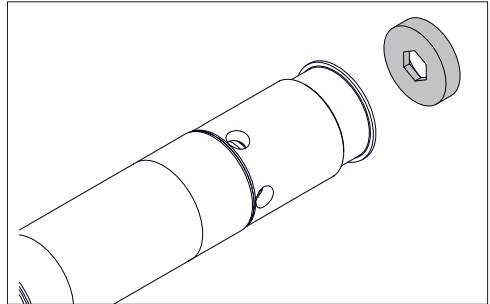

4. Place the raster ring on the seat tube.
→ The bigger diameter of the cone must point downwards (towards the lock nut).

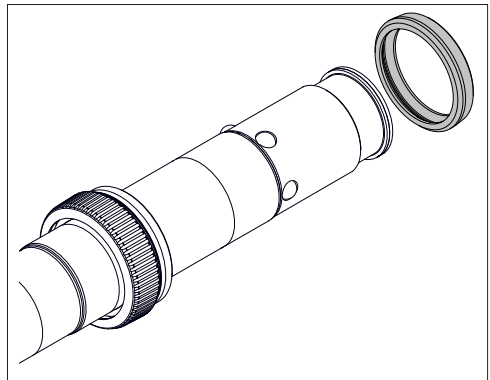

5. Grease the recesses for the latches and insert the latches.

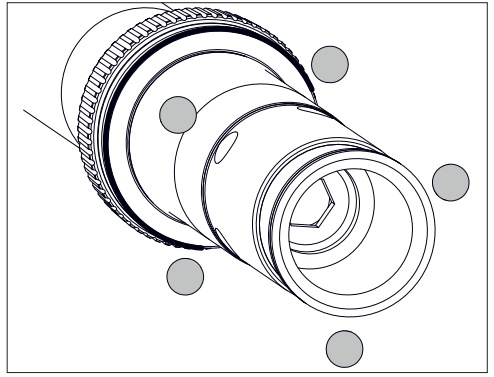

6. Slide a 6 mm hex key from the top into the stop of the release piston and press the release piston slightly downwards.
7. Slide the raster ring upwards over the latches with the release piston pressed down.

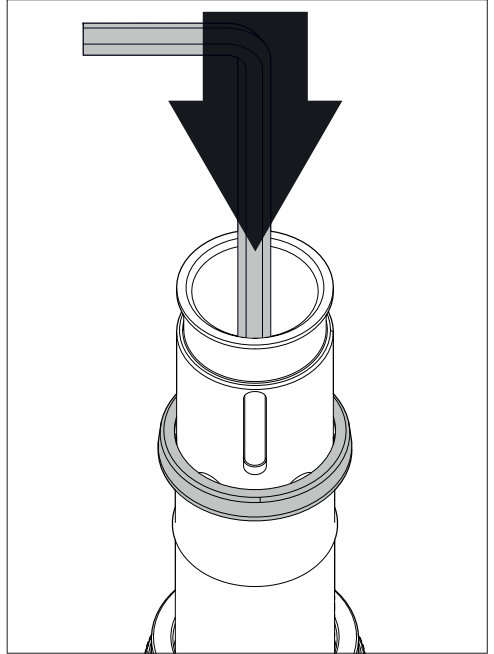

MOUNTING THE QUICKCONNECTOR

Required Material	Specification	Quantity
QUICK CONNECTOR CAP KIT	D 232 Ø27.2 Art. No.: DWKD232X30511S D 232 Ø30.9 Art. No.: DWKD232X30512S D 232 ONE Ø27.2 Art. No.: DWKD232X30514S D 232 ONE Ø30.9 Art. No.: DWKD232X30513S Details, see "Service Kits" on page 7	1*
QUICK CONNECTOR KIT	Art. No.: DWKD232X30515S see "Service Kits" on page 7	1*
universal grease	Slick Honey	as required

*The service kit only needs to be replaced if there is a seat post malfunction (see "Trouble Shooting" on page 15). In case of malfunction, all parts of the required service kit should be replaced.

1. Push the actuating spoke from the top through the release piston.

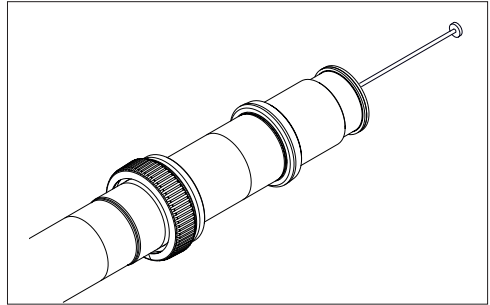

If the lower seat tube cover is replaced, a new O-ring must first be fitted to the seat tube cover.

2. Lightly grease the seat of the O-ring and the O-ring and fit the O-ring on the seat tube cover.

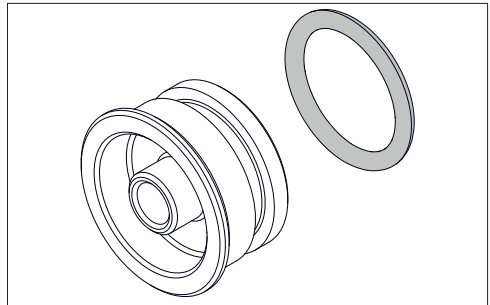

3. Slide the seat tube cover onto the actuating spoke and onto the opening of the seat tube.
4. Slide the O-ring onto the actuating spoke.

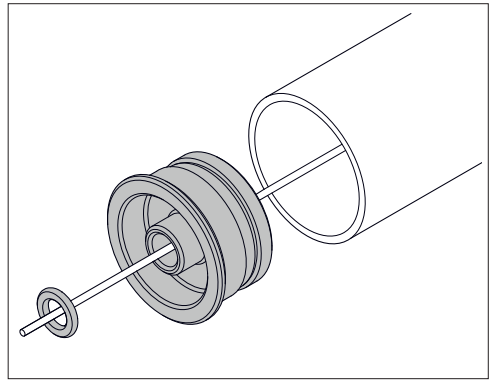

5. Slide the quickrelease housing onto the actuating spoke and put the slider onto the actuating spoke.
6. Push the slider fully in the direction of the seat tube and pull the actuating spoke down as far as possible without actuating the release piston.
7. Clamp the actuating spoke with the clamping screw in the slider using a 2 mm hex key.

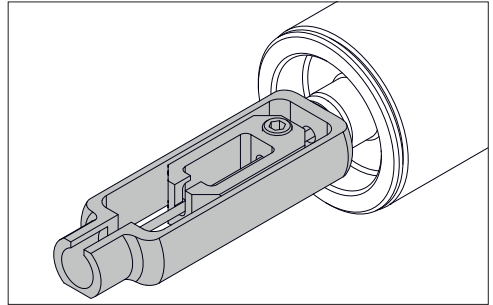

- The tension of the actuating spoke must be neither too high nor too low.
- The slider must not have axial play.
- The raster ring must have no play on the latches.
- If there is play, loosen the clamping screw and clamp the actuating spoke with correct tension.

MOUNTING THE GUIDING PARTS

Required Material	Specification	Quantity
GUIDING KIT	Art. No.: DWKD232X30517S Details, see "Service Kits" on page 7	1*
universal grease	Slick Honey	as required

*The guiding kit should be replaced at every full service (annually or after 200 operating hours).

1. Grease the O-ring.
2. Slide the O-ring onto the seat tube and pull the O-ring over the raster ring.

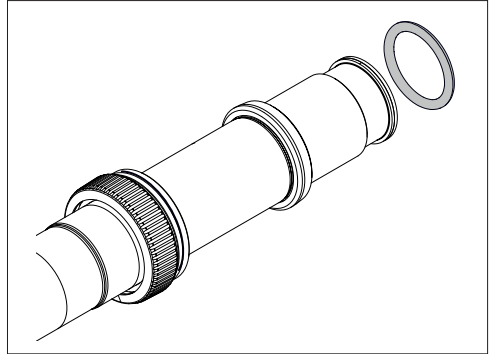

3. Grease the guide ring and the groove for the guide ring in the seat tube.
4. Place the guide ring on the seat tube.

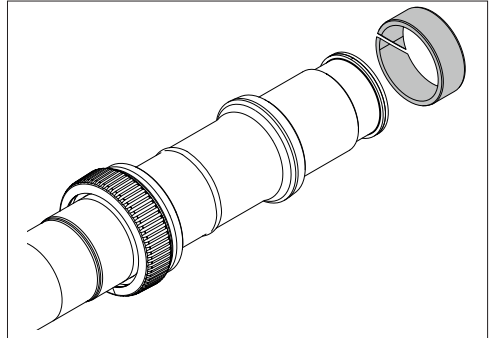

5. Grease the inner and outer surface of the coil spring guide.
6. Insert the coil spring guide into the seat tube.

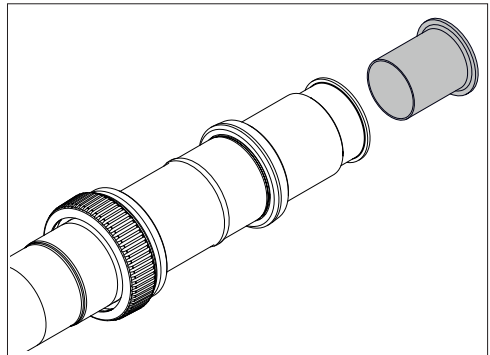

MOUNTING GUIDE KEY

Required Material	Specification	Quantity
SLIDER TUBE KIT	D 232 Art. No.: DWKD232S30508S D 232 ONE Art. No.: DWKD232S30507S Details, see "Service Kits" on page 7	1*
universal grease	Slick Honey	as required

*The service kit only needs to be replaced if there is a seat post malfunction (see "Trouble Shooting" on page 15). In case of malfunction, all parts of the required service kit should be replaced.

1. Lightly grease the guide key and the groove in the seat tube.
2. Place the guide key in the groove in the seat tube and press the guide key completely into the groove in the seat tube with light hammer strokes with a plastic hammer.

Caution: If the guide key is not correctly positioned in the groove, it can be damaged during the press-in process and cause a malfunction.

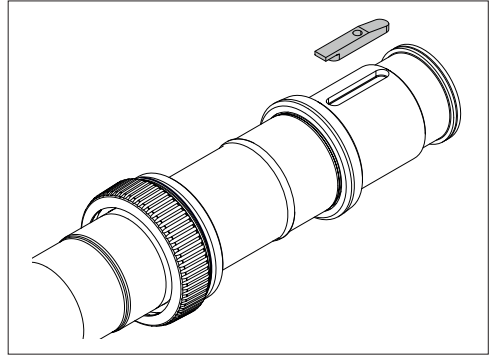

MOUNTING THE SEAT TUBE AND THE SLIDER TUBE

Required Material	Specification	Quantity
REPLACEMENT SPRING	Art. No.: DWKD232N30522S Details, see "Service Kits" on page 7	1*
SEAT TUBE REPLACEMENT	D 232 Ø27.2 Art. No.: DWKD232S30523S D232 Ø30.9 Art. No.: DWKD232S30524S D232 ONE Ø27.2 Art. No.: DWKD232C30525S D232 ONE Ø30.9 Art. No.: DWKD232C30526S Details, see "Service Kits" on page 7	1*
universal grease	Slick Honey	as required

*The service kit only needs to be replaced if there is a seat post malfunction (see "Trouble Shooting" on page 15). In case of malfunction, all parts of the required service kit should be replaced.

1. Grease the coil spring and push the coil spring into the spring guide of the seat tube.
2. Grease the inner surface of the slider tube and the guide parts of the seat tube and slide the slider tube onto the seat tube.
 - The guide key of the seat tube must slide into the guide groove in the slider tube.
3. Press the slider tube downwards against the spring force and screw on the lock nut at the same time.
4. Tighten the lock nut firmly by hand.
 - There must be no visible gap between slider tube and lock nut.

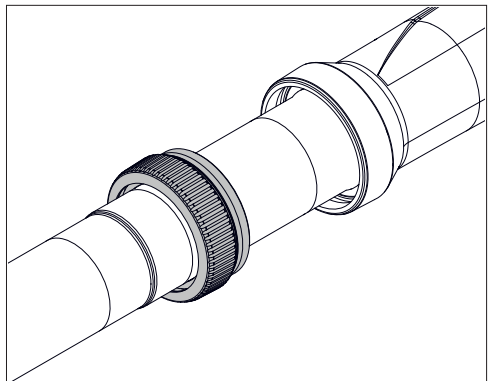
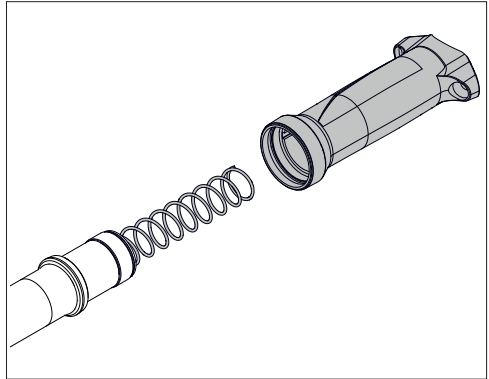

7.4 FITTING THE SEAT POST

MOUNTING THE SEAT POST IN THE BIKE FRAME

1. Hook the shift cable into the Quickconnector.
2. Pull the quickconnector downwards and insert the cable housing.
3. Open the seat post clamp, push the seat post carefully into the bike frame while pulling the cable out of the frame at the same time.
4. Close the seat post clamp.
5. If available, clamp the cable housing with the cable clamps of the bike frame.
6. Tension the cable by turning the cable adjuster on the remote lever.

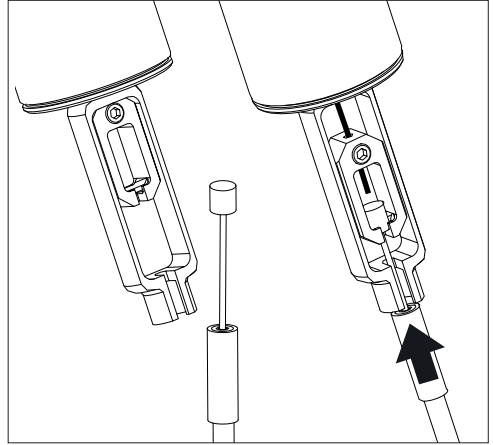

MOUNTING THE L1 REMOTE LEVER ON THE HANDLEBAR

1. Using a 3 mm hex key loosen the fixing screw on the clamp and attach the remote lever on the desired side of the handlebars.
2. Tighten the fixing screw with a max. torque of 1.5 Nm.
→ If the remote lever is fitted on carbon handlebars, the maximum torque may be lower. Observe the handlebar manufacturer's user manual!

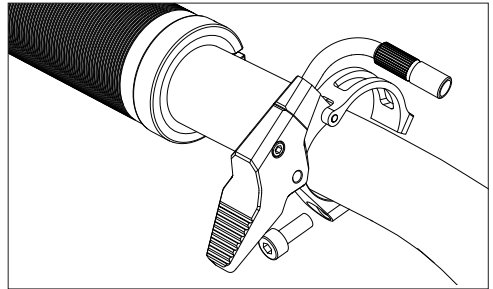

MOUNTING THE L1 TRIGGER REMOTE LEVER ON THE HANDLEBAR

1. Dismount the grip, open the screw of the clamp slightly and slide the clamp onto the left side of the handlebar.
2. Position the remote lever in such a way that the lever can be comfortably reached with the thumb and neither impairs its own function nor interferes with the function of other control elements.
3. Tighten the fixing screw with a torque of max 1.5 Nm. 1.5 Nm.

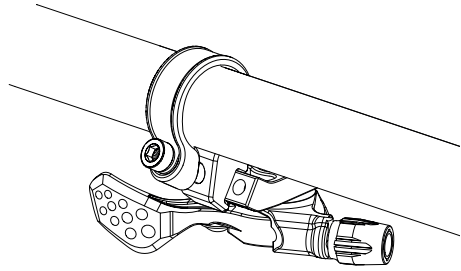

→ If the remote lever is fitted on carbon handlebars, the maximum torque may be lower. Observe the handlebar manufacturer's user manual!

FITTING THE SADDLE AND SEAT CLAMP

1. Using a 5 mm hex key, unscrew the two seat clamp screws leaving a few screw turns still engaged in the barrel nuts.
2. Lift the upper seat clamp and pull out the lower saddle clamp to the side.

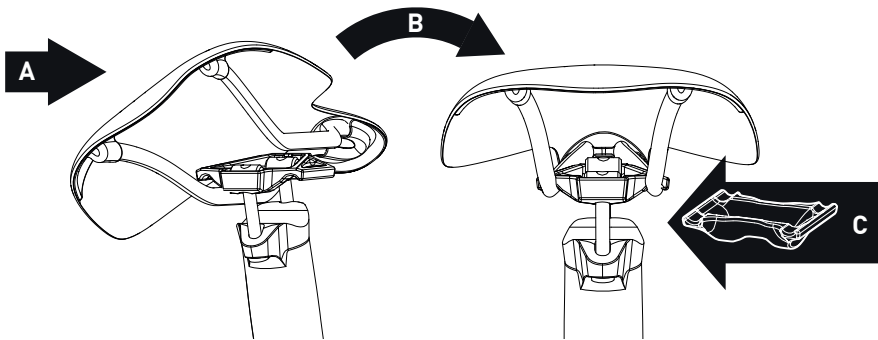

3. Lift the upper seat clamp, tilt the saddle to the side and push in the first saddle brace underneath the upper seat clamp (A).
4. Tilt the saddle over the upper seat clamp, and attach the saddle so that both saddle braces lie below the upper seat clamp (B).
5. Pull up the upper seat clamp and the saddle, and push the lower seat clamp in underneath the saddle (C) from the side.
6. Tighten the seat clamp screws alternately until the desired saddle tilt has been adjusted.
 - When tightening the seat clamp screws, make sure that the barrel nuts are not twisted and lie in the recesses of the upper saddle clamp.
7. Tighten the seat clamp screws to a torque of 5 Nm.
 - If you are fitting a saddle with carbon braces, the maximum torque may be lower. Observe the saddle manufacturer's user manual!
 - If the seat clamp screws (4) should loosen slightly during the ride, a medium thread lock can be used.

DT SWISS AG

Längfeldweg 101
CH - 2504 Biel/Bienne
service.ch@dtswiss.com

DT SWISS, INC.

2493 Industrial Blvd.
USA - Grand Junction, CO 81505
techusa@dtswiss.com

DT SWISS (FRANCE) S.A.S.

Parc d'Activites de la Sarrée
Route de Gourdon
F - 06620 Le Bar sur Loup
service.fr@dtswiss.com

DT SWISS ASIA LTD.

No.5, Jingke 5th Rd., Nantun District
Taichung City 408
Taiwan (R.O.C.)
service.tw@dtswiss.com

DT SWISS DEUTSCHLAND GmbH

Albert-Einstein-Strasse 3
59302 Oelde
Germany
service.de@dtswiss.com

DT SWISS POLSKA Sp. z o.o.

ul. Towarowa 36
PL-64-600 Oborniki
Poland
service.pl@dtswiss.com

Subject to technical alterations, errors and misprints excepted.

All rights reserved.

© by DT SWISS AG

www.dtswiss.com

DXD1000003114S



7 613052 209760 >